



## Steam-Vacuum Board

Models 46SVB/SVBA & 52SVB/SVBA



Model 46SVB

- Pleater pad included
- Up-Air feature on Models 46/52SVBA
- Foot pedals allow operator to control flow of steam and vacuum
- Pivoting catch rack and iron tray included for operator convenience
  - Forenta's fabricated buck design with flat surface provides uniform steam and vacuum throughout entire board
  - Options include: Integrated Vacuum, Water Spray, Sleeve Board, and Garment Hanger

[www.forentausa.com](http://www.forentausa.com)

Tel: 423-586-5370 • Email: [info@forentausa.com](mailto:info@forentausa.com)

Made in USA

## Steam-Vacuum Board SPECIFICATIONS

### Steam connections:

- 1/2 NPT for supply and condensate
- 75-85 psi (0.52-0.59 MPa)
- Steam consumption at 80 psi(0.55 MPa):
- 0.5 BHP (17.2 lb/hr)(7.8 kg/hr)

### Vacuum connection (Central):

- 1-1/4 NPT
- 20-30 inches of water (50-75 millibar)
- 75 cubic feet/minute (127 cubic meters/hour)

### Electrical connection for: (46SVBA-120 & 52SVBA-120)

- 120 VAC single-phase, 60 Hz, 8.1 amps, (UL motor)
- Power cord connected

### Electrical connection: (46SVBA-230 & 52SVBA-230)

- 220 VAC single-phase, 60 Hz, 4.1 amps, (UL motor)
- Power cord connected

### Electrical connection for optional 120 volt vacuum:

- 120 VAC single-phase, 60 Hz, 8.1 amps, (UL motor)
- Power cord connected

### Electrical connection for optional 220 volt vacuum:

- 220 VAC single-phase, 60 Hz, 4.1 amps, (UL motor)
- Power cord connected

### Optional hand iron electrical connection

- 115 VAC or 230 VAC single-phase, 50/60 Hz
- Conduit connection
- 800 watts
- Approximate hourly consumption: 0.5 KWH

### Optional water spray cold water connection:

- 1/4 NPT
- 40-80 psi (0.3-0.55 MPa)
- 1 gallon/minute (3.8 liter/minute)

## BUCK DIMENSIONS (unpadded)

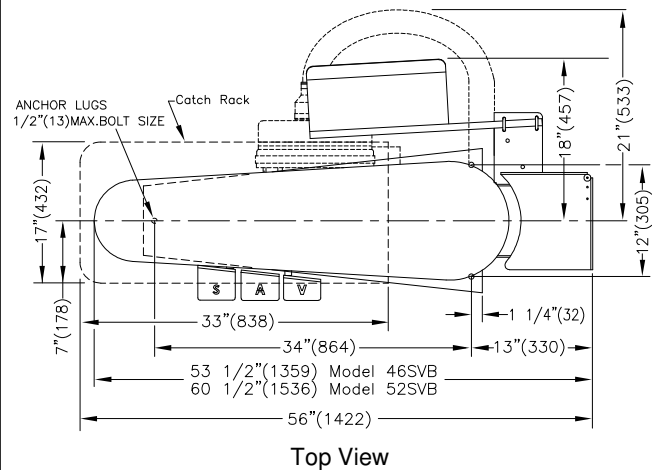
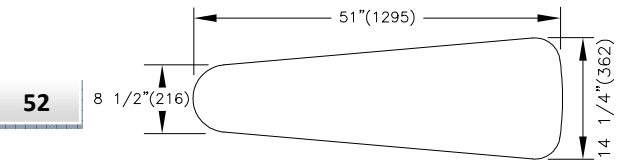
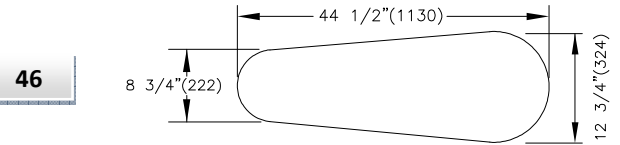

## Optional Attachment Kits

	46SVB / 52SVB	46SVBA-120 / 52SVBA-120	46SVBA-230 / 52SVBA-230
K-563 All-Steam Iron Attachment	•	•	•
K-564 Steam/Electric Iron Attachment, 115 Volt	•	•	•
K-565 Steam/Electric Iron Attachment, 230 Volt	•	•	•
K-566 Water Spray	•	•	•
K-569 Garment Hanger	•	•	•
K-570 Sleeve Board	•	•	•
K-701-1 Integrated Vacuum, 120 Volt, 1 Ph.	•		
K-701-2 Integrated Vacuum, 230 Volt, 1 Ph.	•		
K-706-1 Integrated Vacuum, 120 Volt, 1 Ph.		•	
K-706-2 Integrated Vacuum, 230 Volt, 1 Ph.			•