



Flatwork Press

Model A6024VLFV

Model A6024VLFP



A6024VLFV

- Dual buck steam valves
- Hot-head with bar control
- Dual vacuum valves on VLFV
- Can also be used as a double legger press
- Designed for all flatwork; drapes, linens, etc.
- Model A6024VLFV with vacuum - Model A6024VLFP without vacuum

www.forentausa.com

Tel: 423-586-5370 • Email: info@forentausa.com

Made in USA

Specifications

Models A6024VLFV & A6024VLFV

Steam and Air connection		A6024VLFV	A6024VLFV
Steam Inlet	NPT	1/2"	1/2"
Steam Outlet	NPT	1/2"	1/2"
Rec. steam pressure	PSIG kPa	100-125 621-861	100-125 621-861
Steam consumption	BHP kg/hr	1.5 23.4	1.5 23.4
Compressed air	NPT	3/8"	3/8"
Air consumption	free air/cycle at 68psig free air/cycle at 470kPa	0.31 CU.FT. 8.8 liters	0.31 CU.FT. 8.8 liters
Rec. air pressure	PSIG kPa	68 470	68 470
Vacuum connection	NPT	1 1/4"	-
Weight (crated)			
Shipping	lbs kg	1090 494	1090 494

1 Control bar	4 Air connection
2 Steam Outlet connection	5 Vacuum connection
3 Steam connection	6 Water connection (for optional water spray)

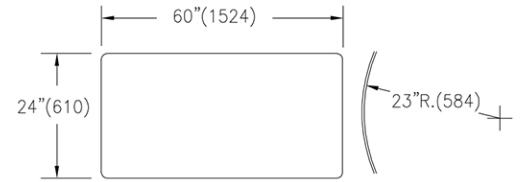

Buck Dimensions

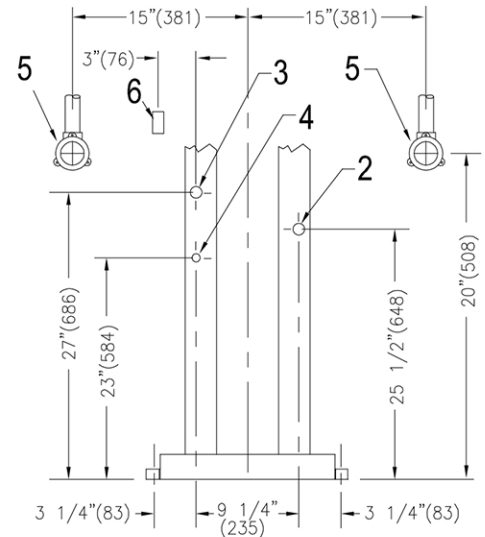

REAR VIEW

